

CONTROL THROWS
 RUDDER: 1" LEFT AND 1" RIGHT MEASURED AT THE T. E.
 STABILATOR: 3/8" UP AND 3/8" DOWN MEASURED AT T. E.

NOTE: THE TERM "AIR-PLY" REFERS TO LIGHT WEIGHT POPLAR PLYWOOD.

NOTE: ALL WOOD IS BALSA UNLESS NOTED OTHERWISE.

CONSTRUCTION SHEET 1 OF 2
 © RCM ALL COMMERCIAL RIGHTS RESERVED.

SAGITTA 600

DESIGNED BY LEE RENAUD
 DRAWN BY TIM RENAUD
 PLANS BY Bob Wallace

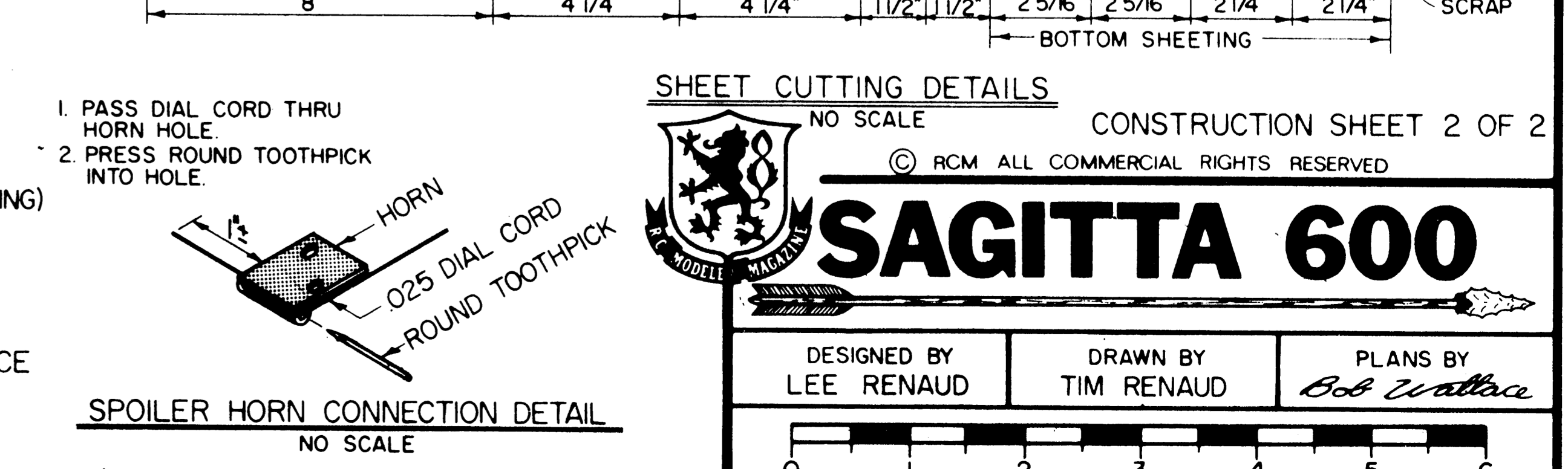
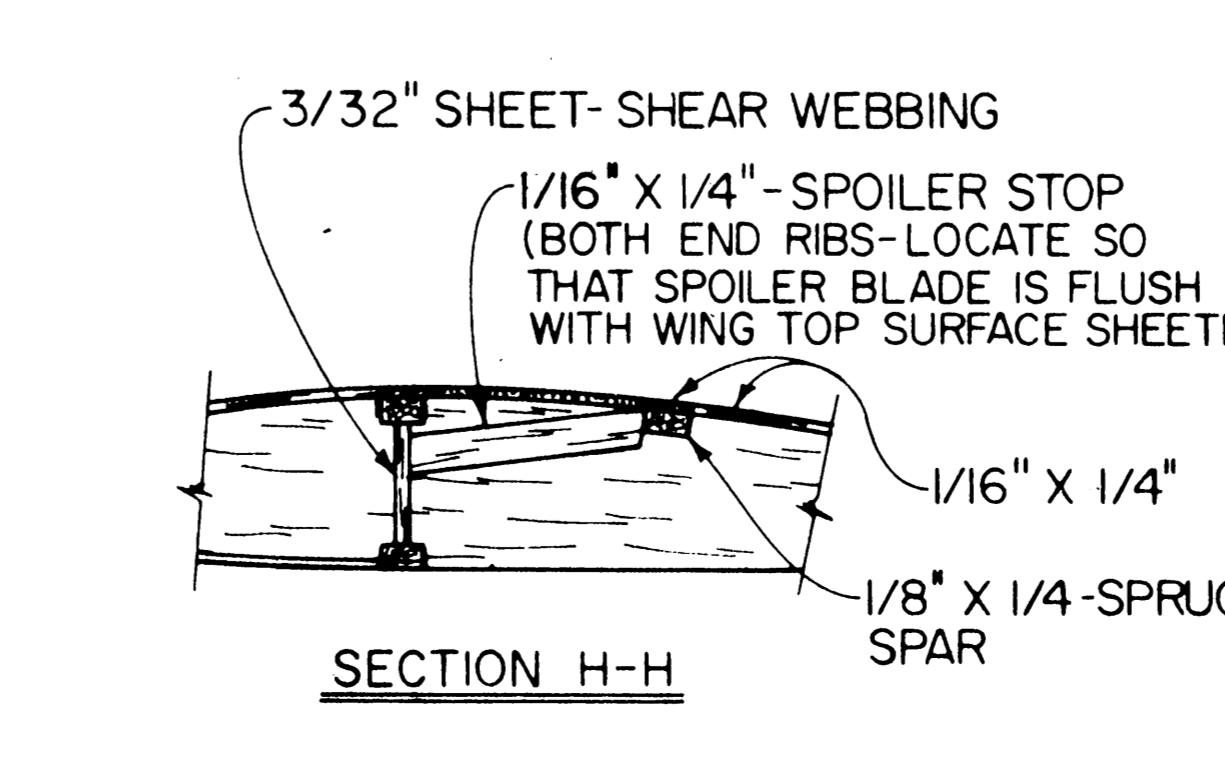
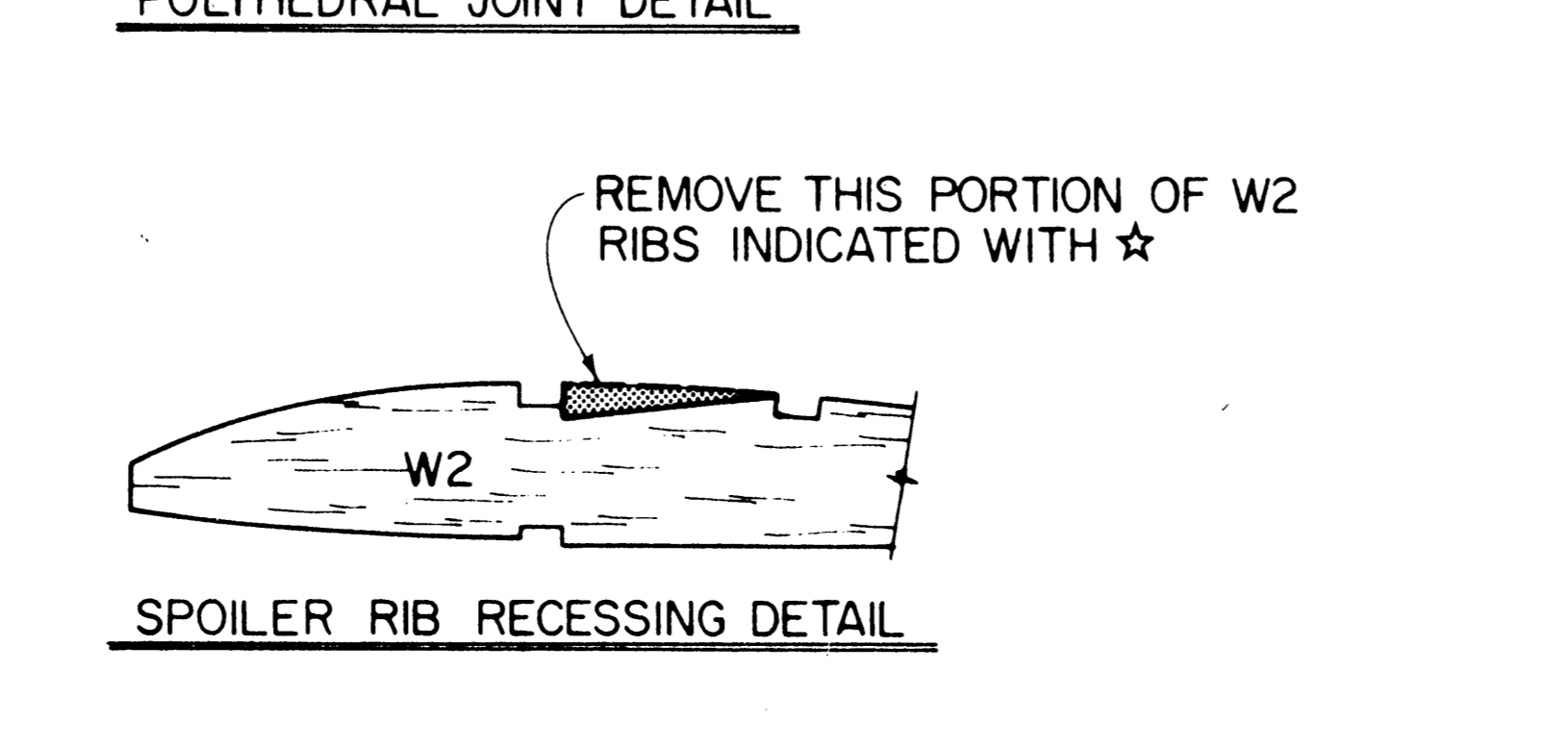
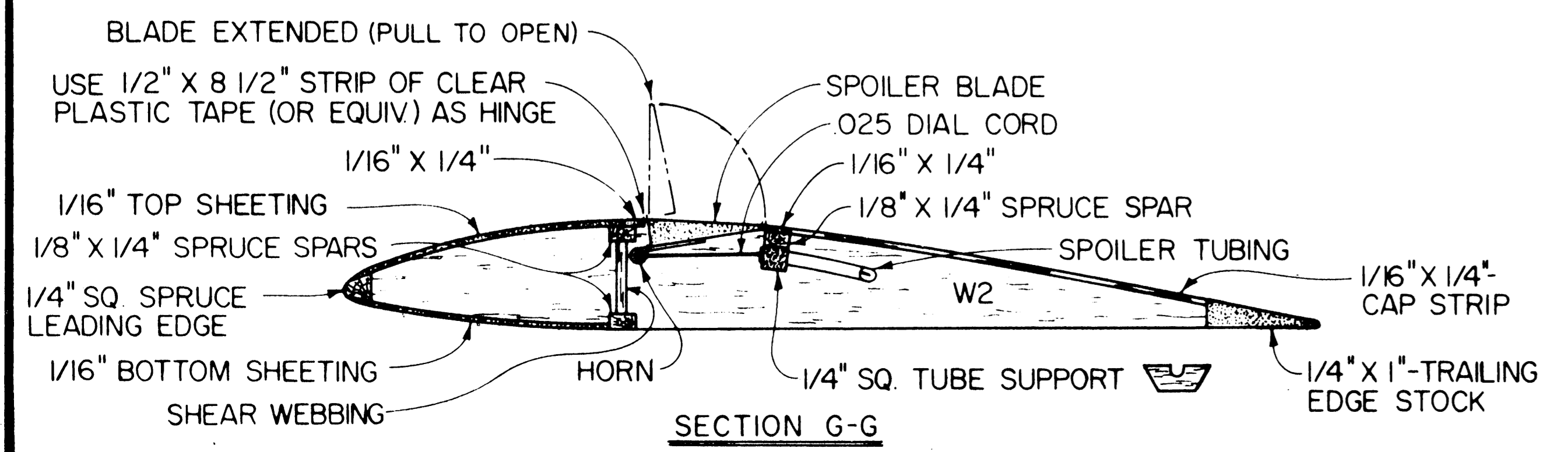
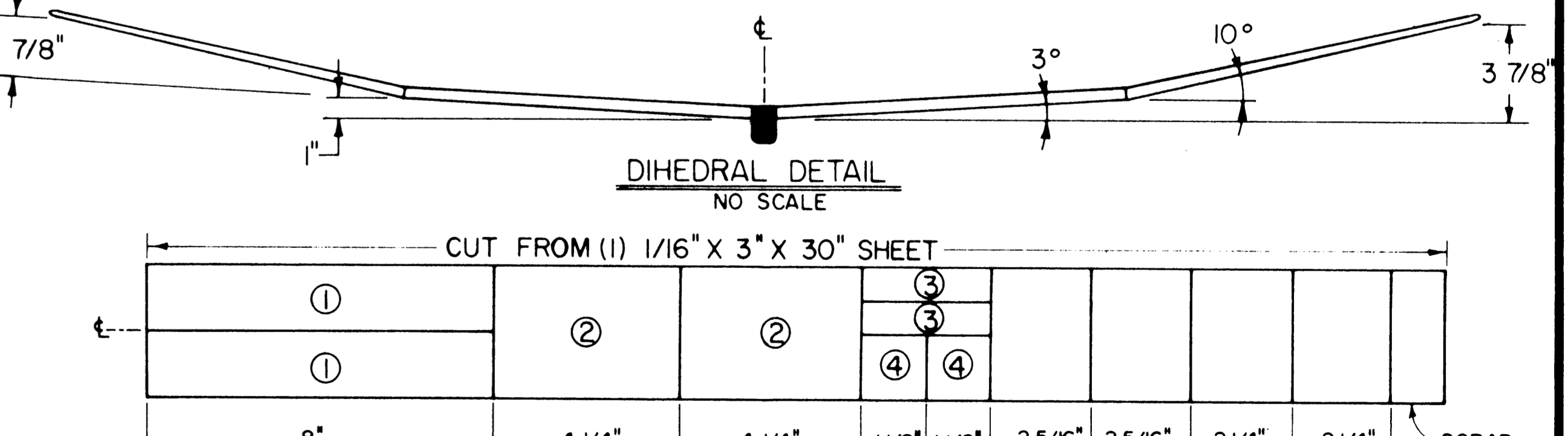
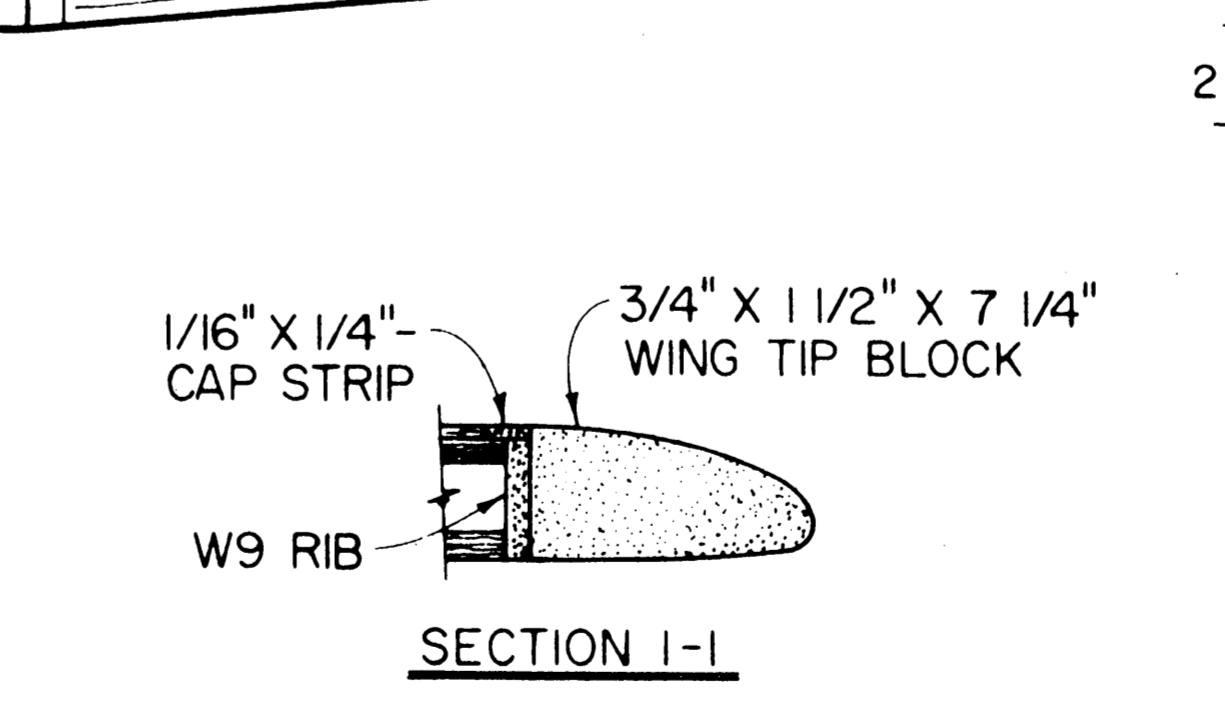
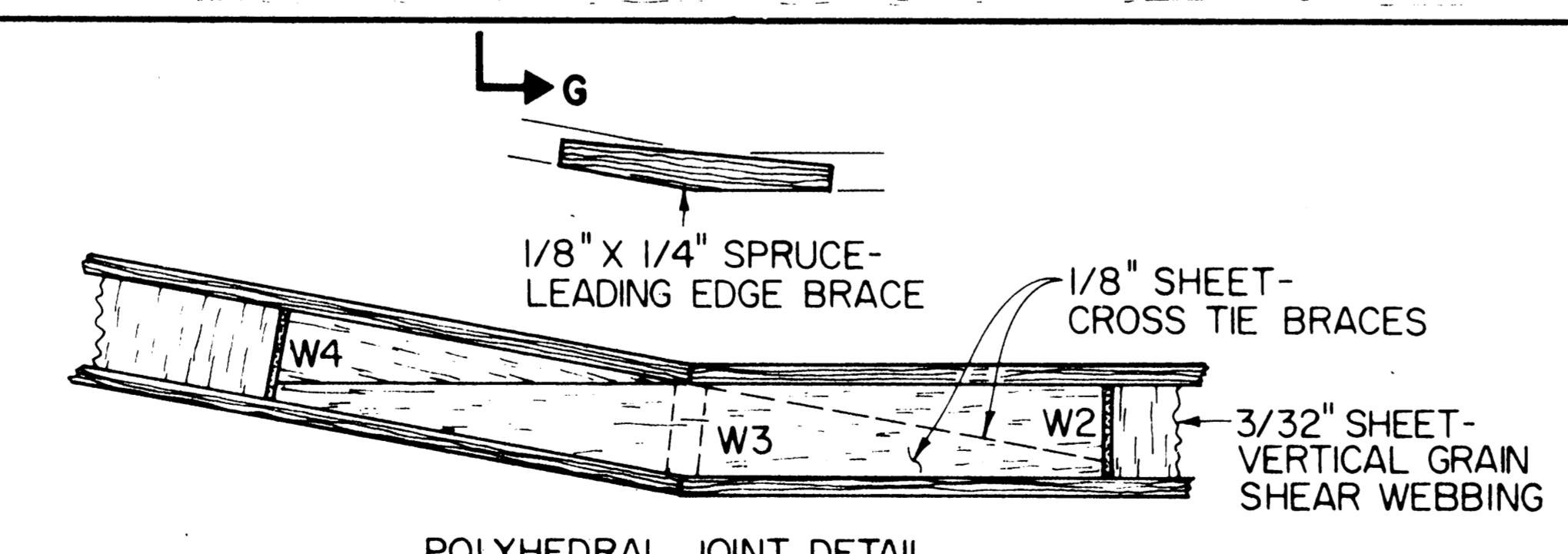
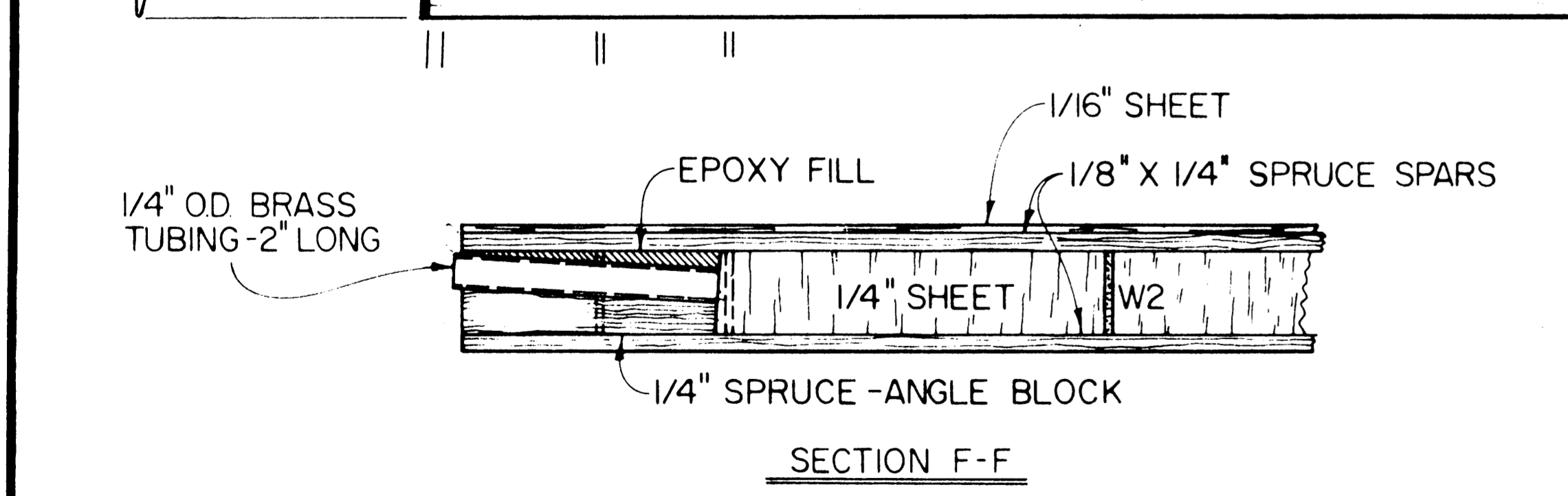
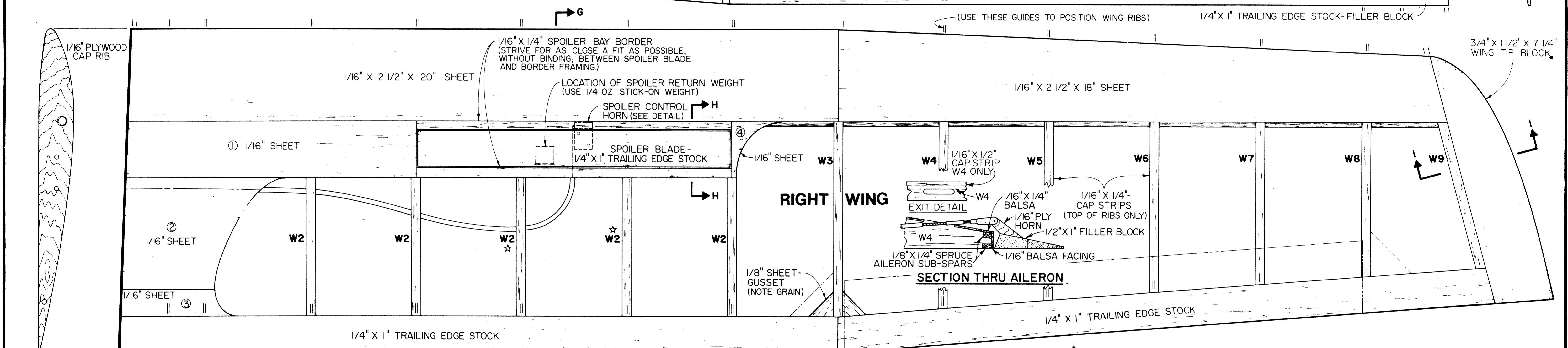
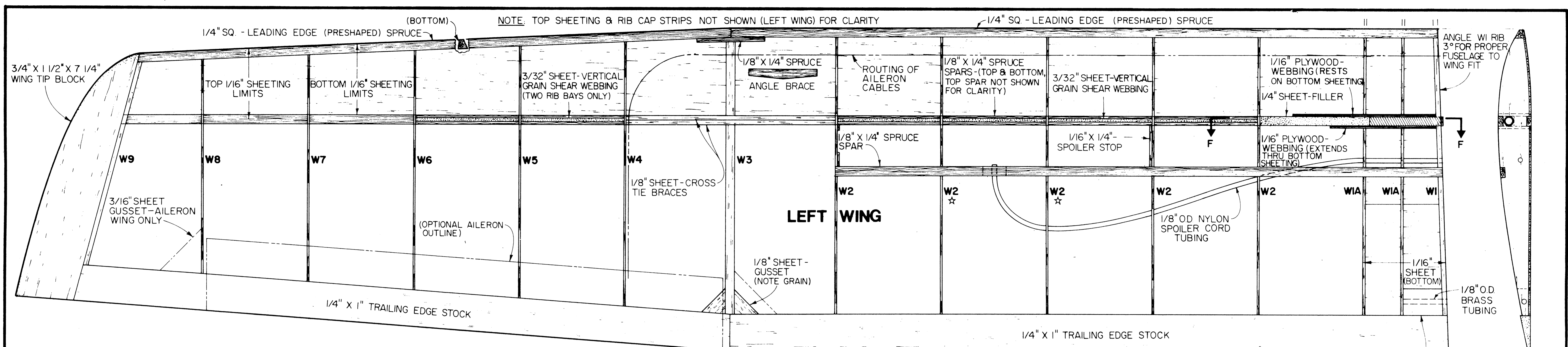

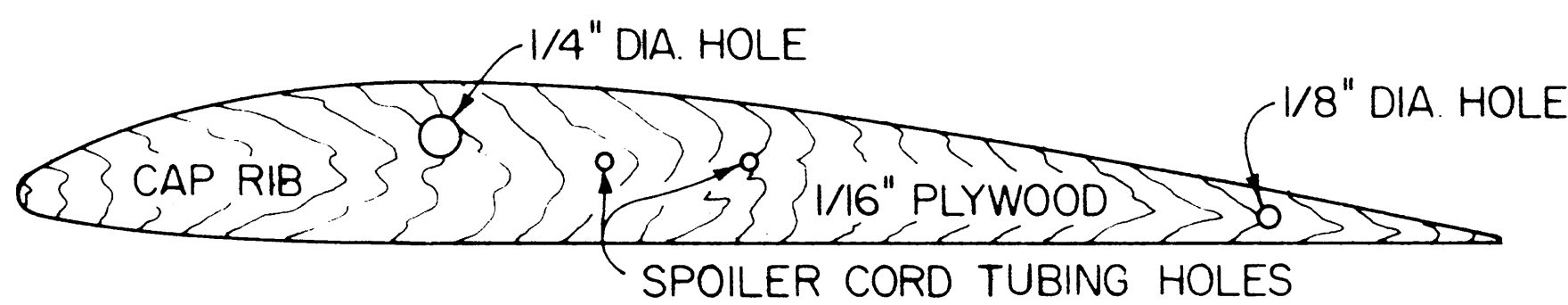
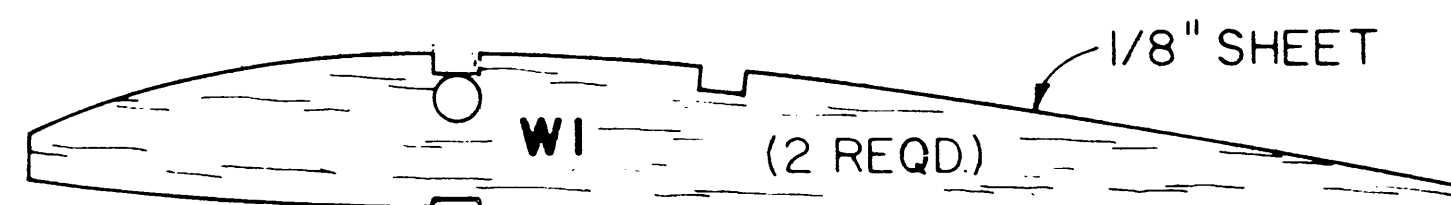
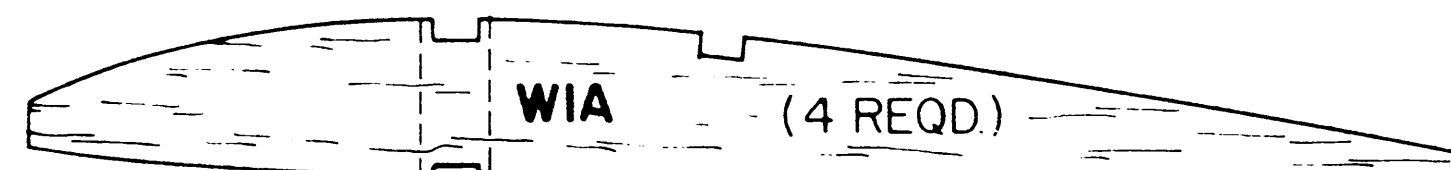
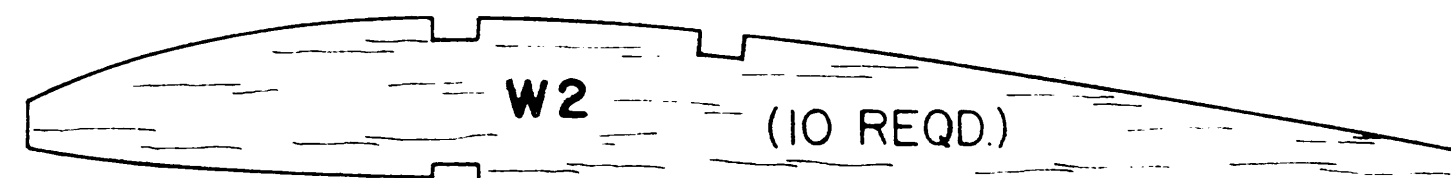
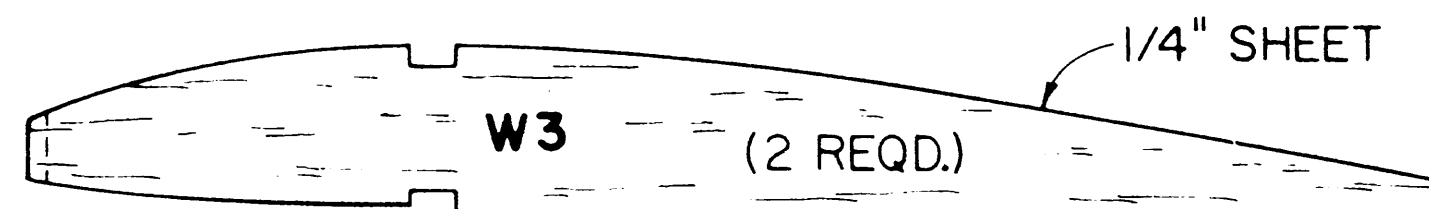
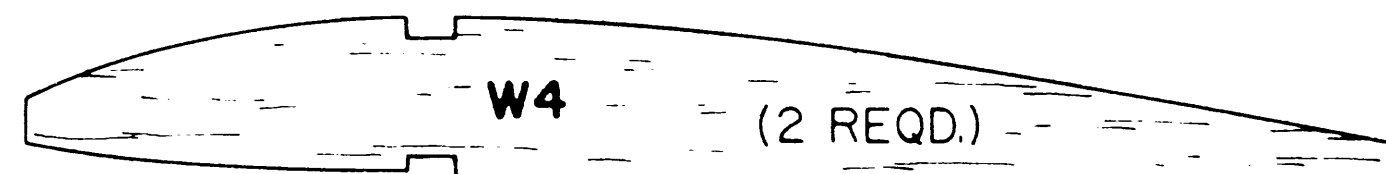
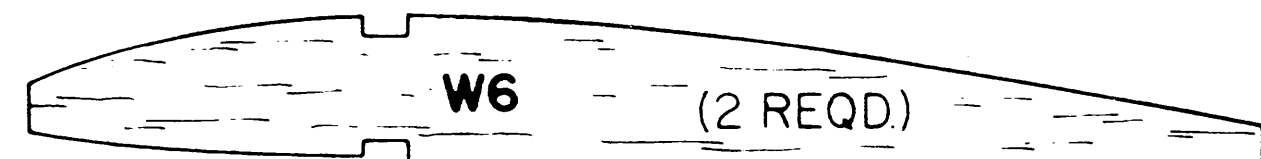
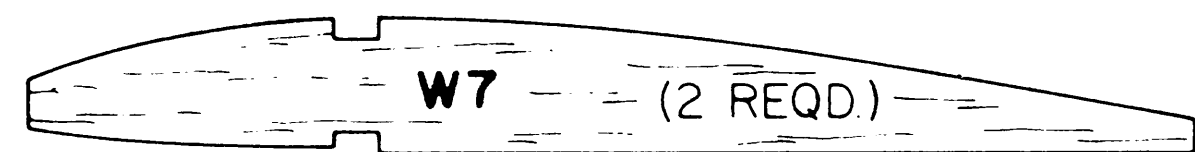
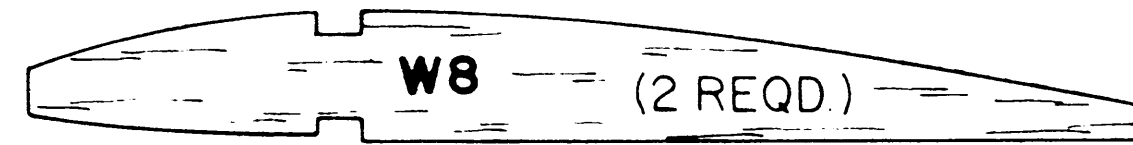
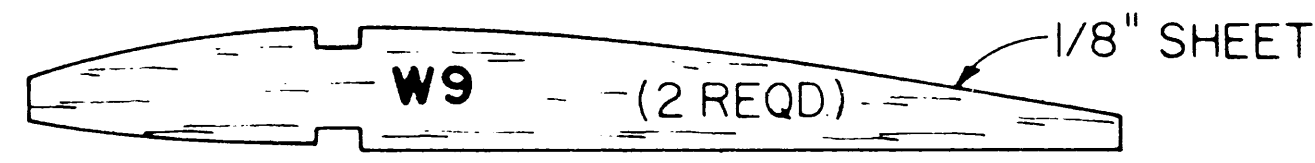

ALL WING RIBS ARE 1/16" SHEET, EXCEPT W1, W3, & W9

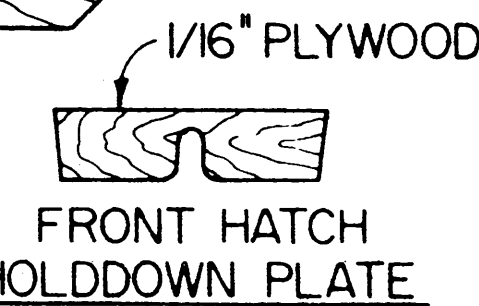
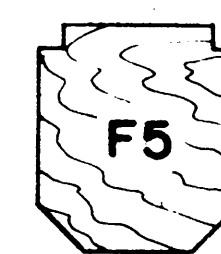
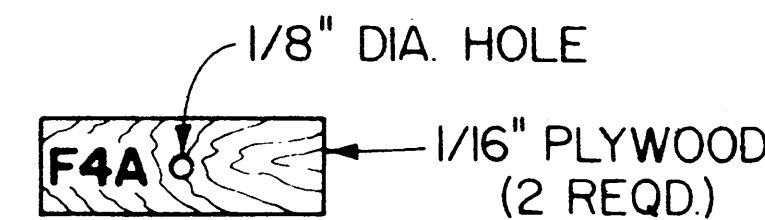
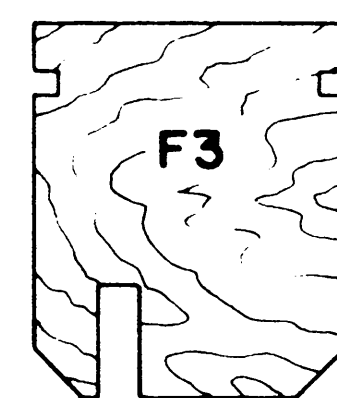
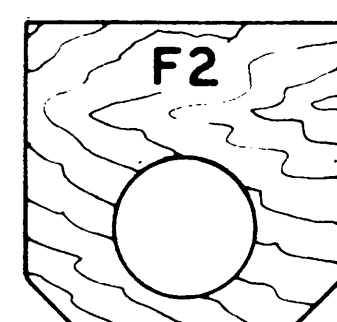
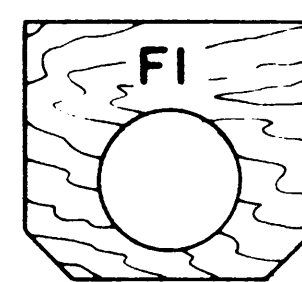
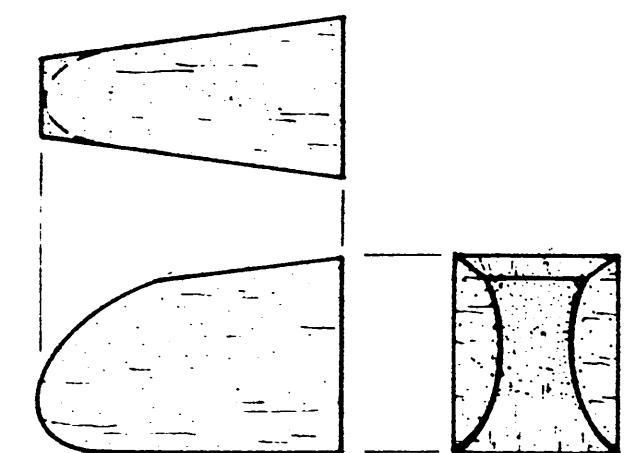
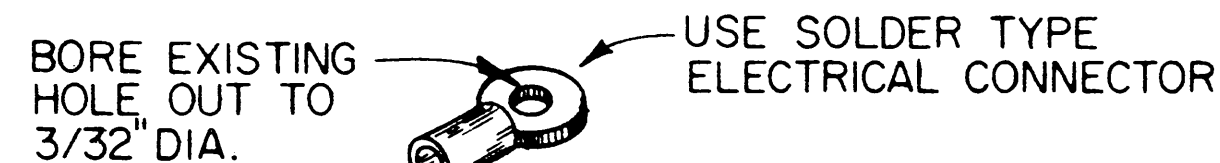
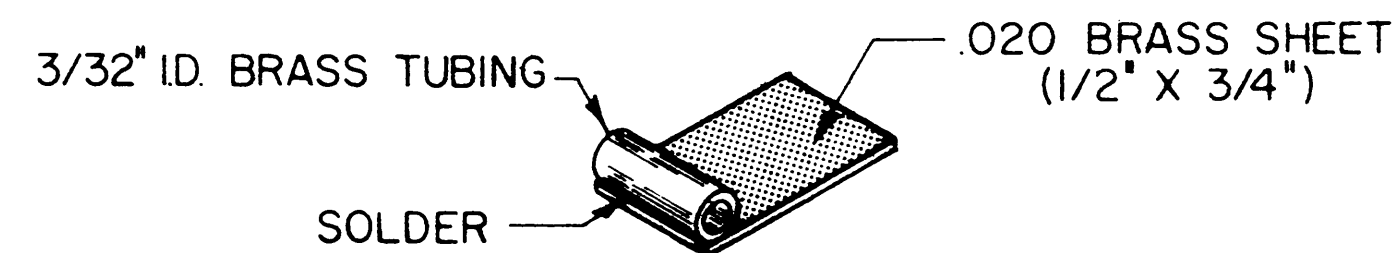
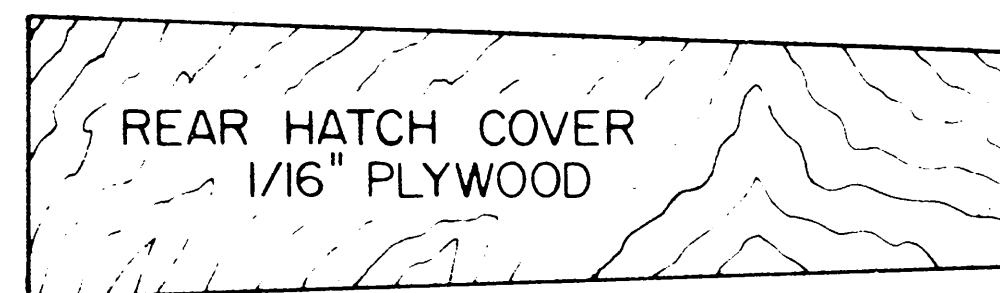
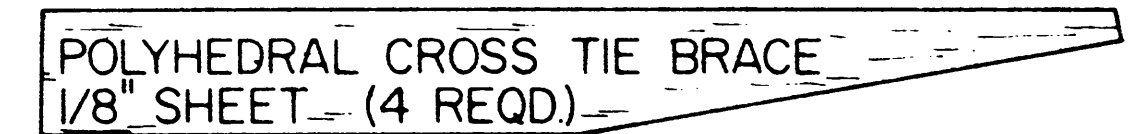
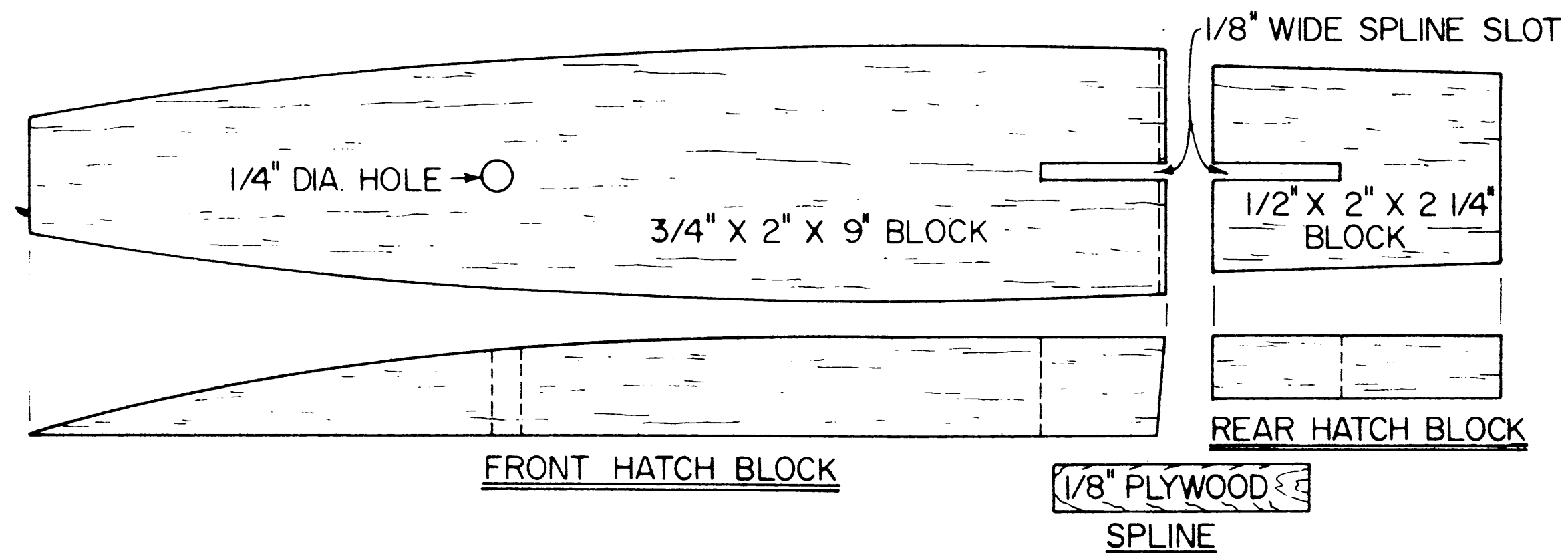
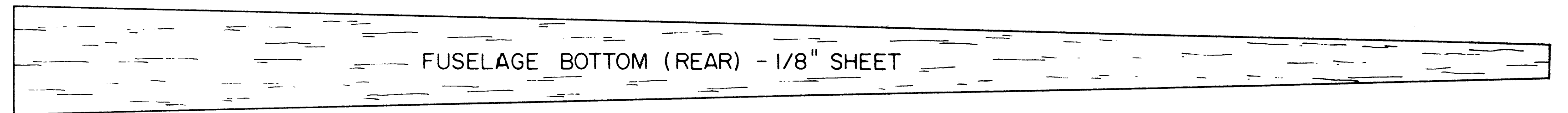
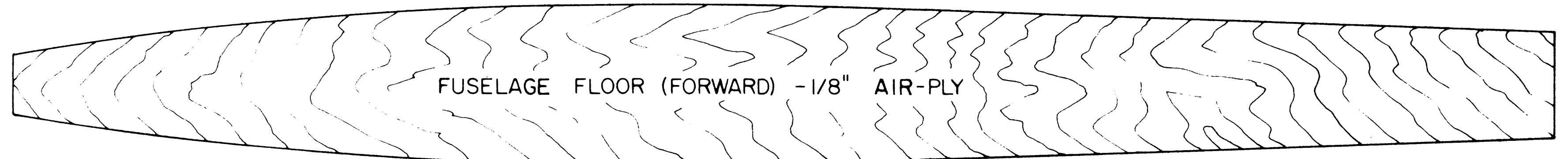

NOTE: ALL FUSELAGE FORMERS ARE 1/8" AIR-PLY, UNLESS NOTED OTHERWISE.

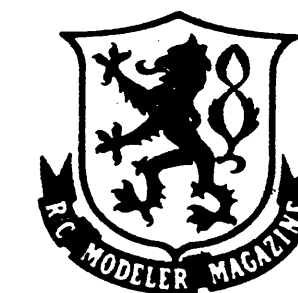

TEMPLATE SHEET

© RCM ALL COMMERCIAL RIGHTS RESERVED

SAGITTA 600

DESIGNED BY LEE RENAUD

DRAWN BY TIM RENAUD

PLANS BY Bob Wallace

